

Section B-B  
(1 : 20)

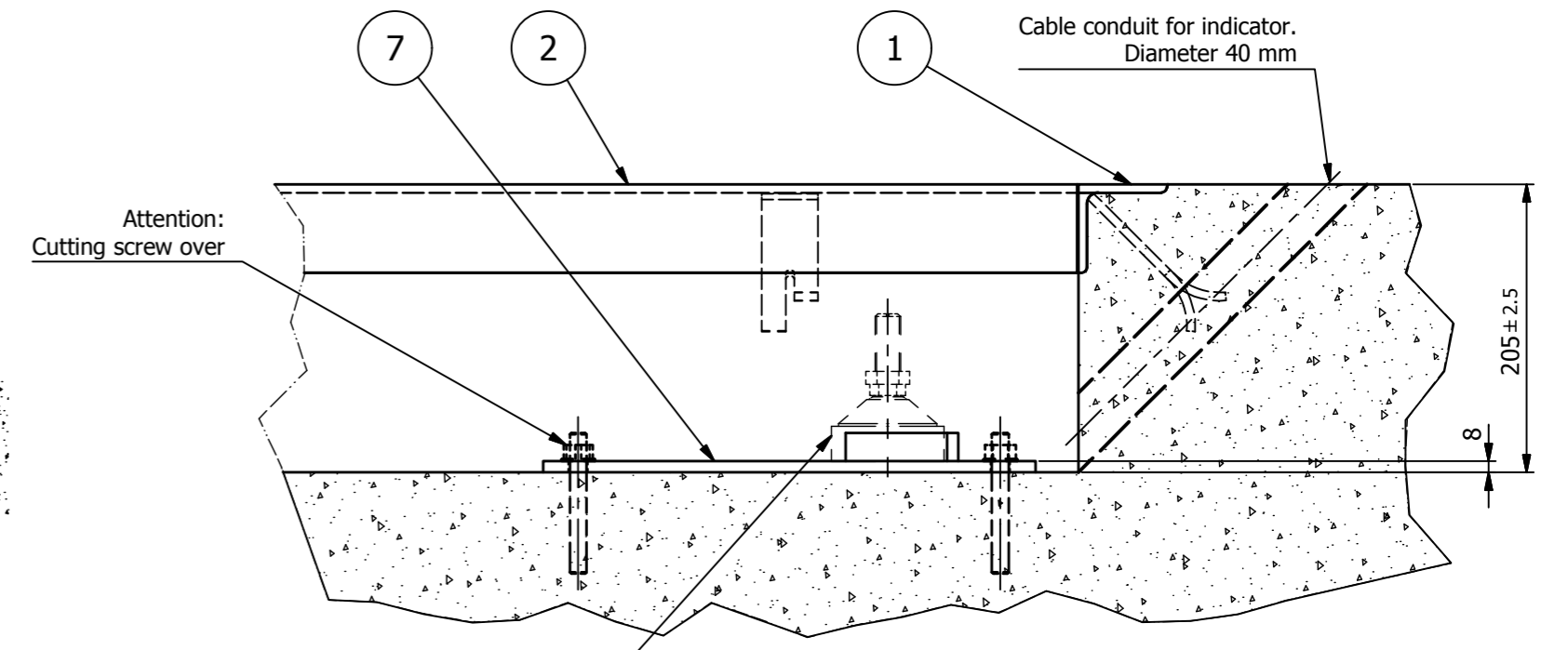

Detail A  
(1 : 5)

DIMENSION TABLE (mm)		
MODEL	A	B
L=5000	5020	4749
L=6000	6020	5749

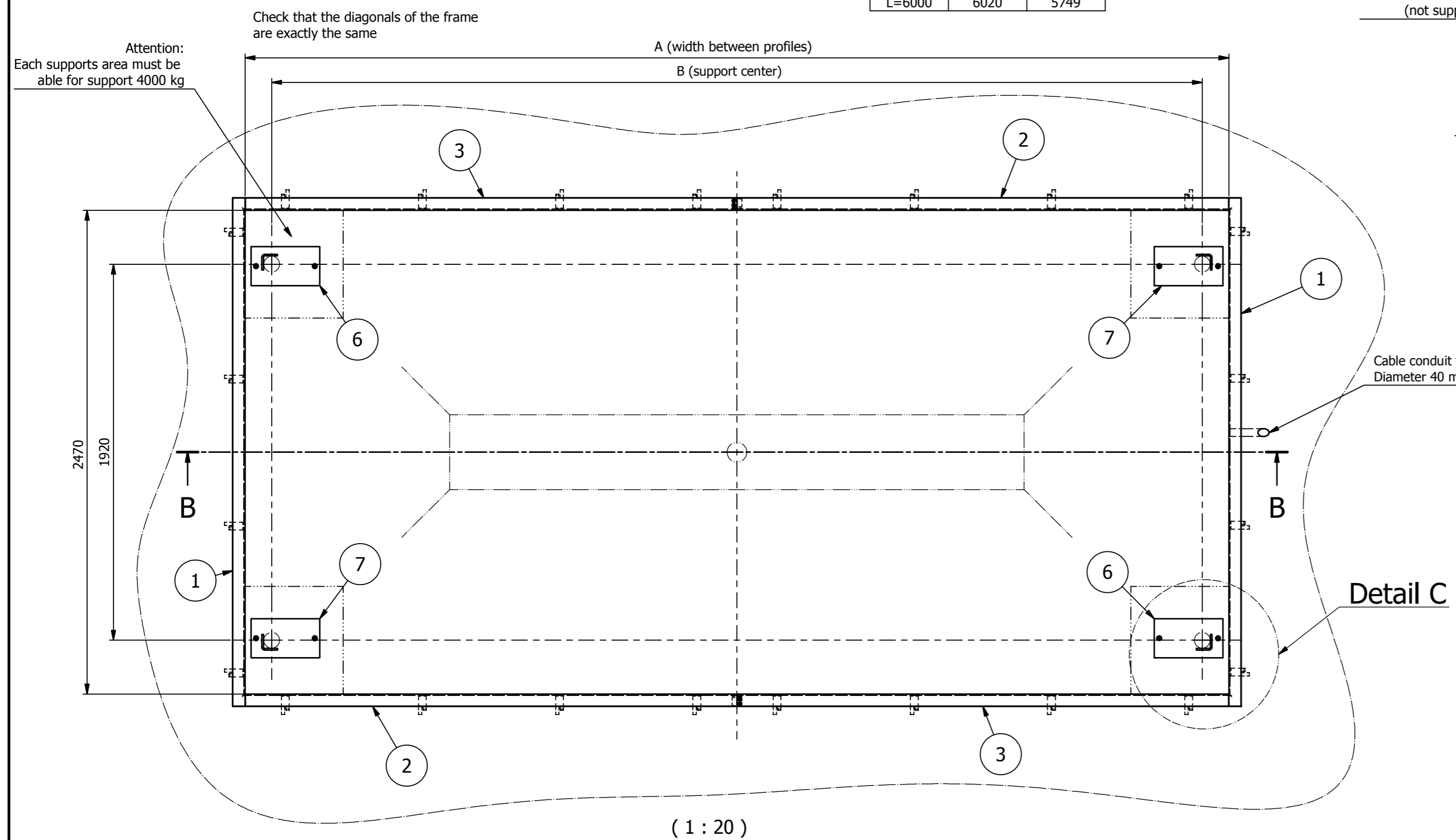

(1 : 20)

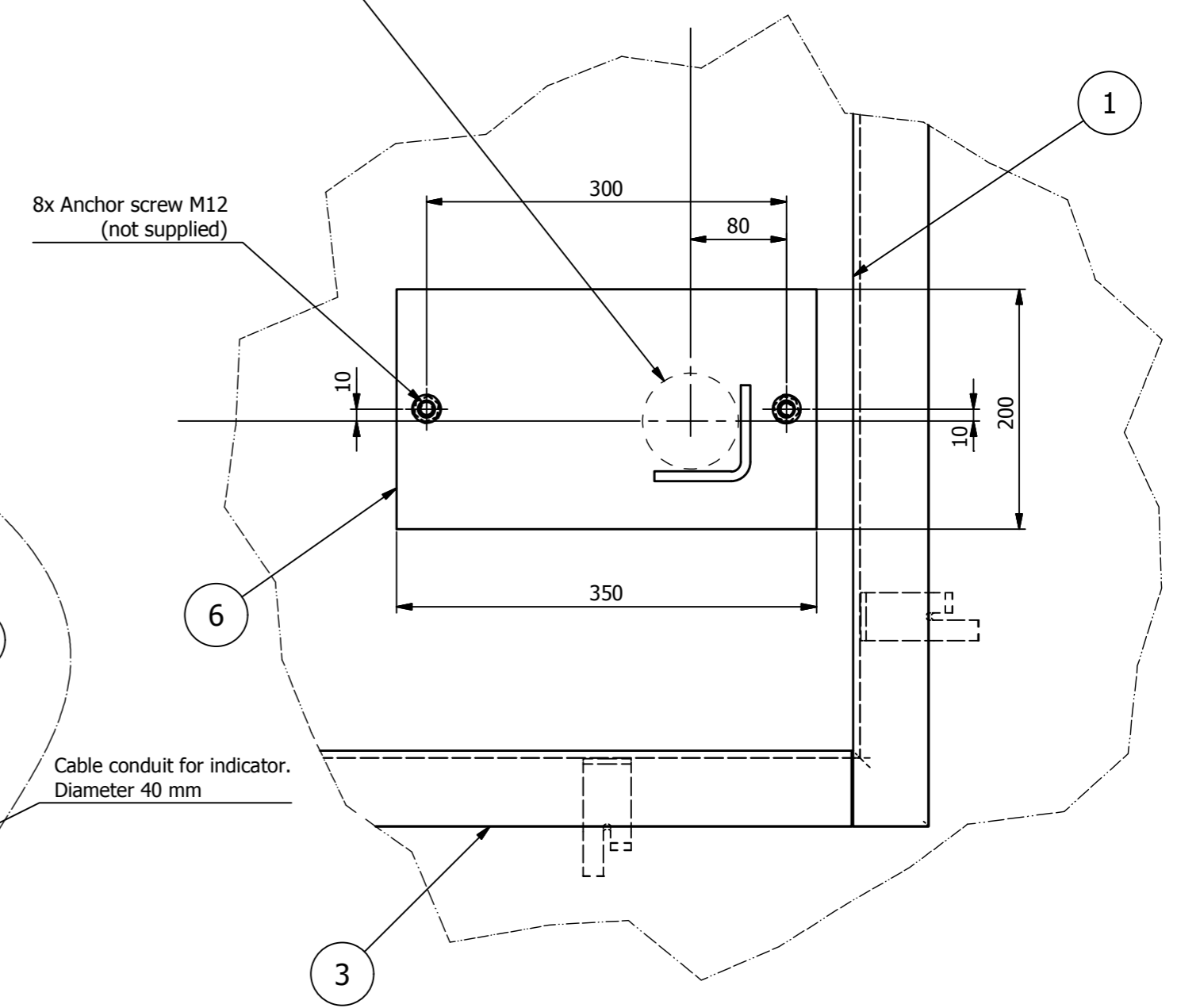

Detail C  
(1 : 5)

Elem.	Description	Quant	Material	Reference
7	Support plate for SPEED (Symmetrical)	2	Steel	
6	Support plate for SPEED	2	Steel	
5	Hexagon nut DIN 934 (ISO 4032) - M8	8	S.steel	
4	Countersunk flat screws DIN 7991 M8x12	8	S.Steel	
3	Profile L63x63x6 T2	2	Steel	
2	Profile L63x63x6 T1	2	Steel	
1	Profile L63x63x6 Short	2	Steel	

RV	DESCRIPTION	DATE
0	First edition	10/01/2016

	SPEED	
	Pit frame for L=5000 & 6000	
Drawing for facility work		09-45-ASSE-2000-EN
General Scale: 1:10	Sheet: 01/01	Drawing paper: A2

Drawing property of "Gram Precision, S.L."  
 Exhibition, total or partial copy, or use in manufacturing processes  
 without the written consent is forbidden